

Súla S1, 1:20

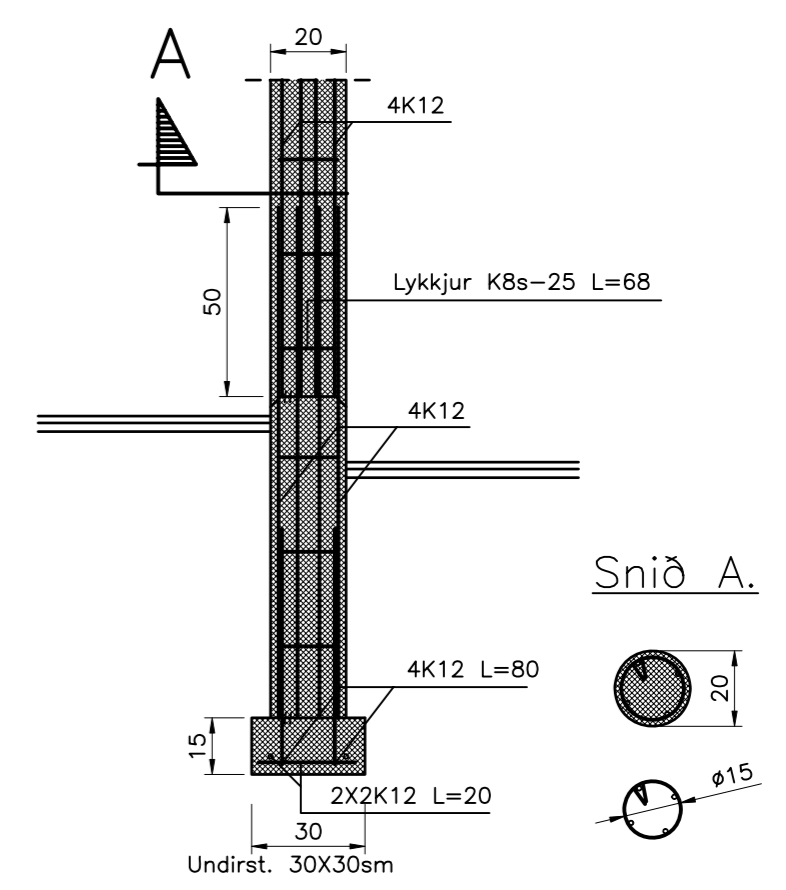

Súla S2, 1:20

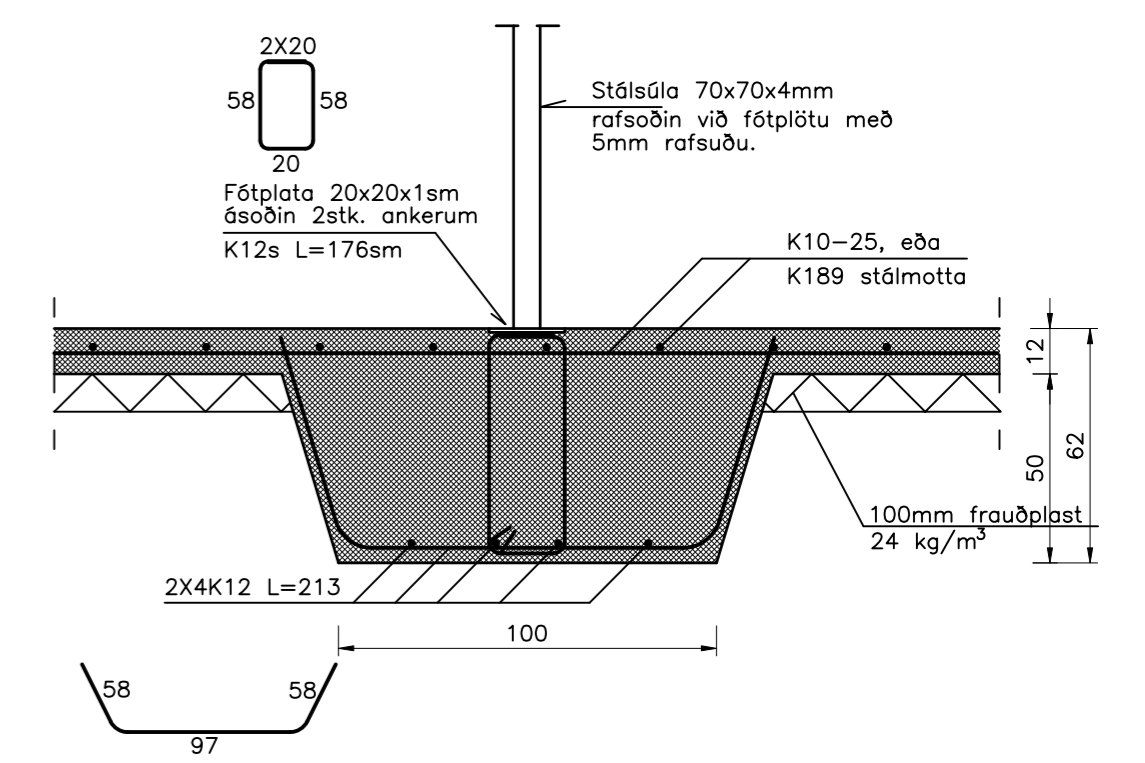

Ath.  
Sjá almennar skýringar á tekn. nr. 1800.

# H.S.Á. TEIKNISTOFA

HARA ehf. · SUNNÚHLÍÐ 12 · 603 AKUREYRI · kt. 531101-2860  
sími 464-6800 · fax 464-6801 · hara@hara.is · www.hara.is  
HARALDUR S. ÁRNASON · kt. 120149-2539  
STEINMAR H. RÖGNVALDSSON · kt. 140574-3769

|                                   |         |           |            |             |
|-----------------------------------|---------|-----------|------------|-------------|
| VERKHEITI                         |         |           |            |             |
| <b>Blikatjörn 6, Reykjanesbæ.</b> |         |           |            |             |
| HEITI TEIKNINGAR                  |         |           |            | VERK NR     |
| Grunnmynd undirstaða og snið.     |         |           |            | 04-329      |
|                                   |         |           |            | TEIKNING NR |
|                                   |         |           |            | 1701        |
| HANNAÐ                            | TEIKNAD | YFIRFARID | DAGS       | KVARDI      |
| SHR                               | SHR     |           | 30.10.2005 | 1:50/20     |
| BREYTT                            |         |           |            |             |
| 1                                 |         | 2         | 3          | 4           |
|                                   |         |           |            | 5           |

Breyting nr. 1:  
Snið S1 breytt.

